

Building Guide

ILLOWA Chapter of ICC



Single Family Residential One Story Detached Garage

How to use this guide:

This guide was designed to assist the do-it-yourselfer create a construction plan to build a simple one story detached garage using conventional construction methods. Non-conventionally constructed garages will require a design professional.

1. **Complete this Building Guide** by filling in the blanks on page two and three and indicating which construction details will be used.
2. **Provide a Site Plan** showing the dimensions of your project and its relationships to existing buildings or structures, utilities, property lines and easements. In addition to project dimensions, your plot plan must also show direction of trusses, location and detail of wall bracing, and any other pertinent information not shown on the section drawing.
3. **Now you are ready to apply for your building permit.** The majority of permit applications can be processed with little delay. The submitted documents will help determine if the project is in compliance with building codes, zoning ordinances and other applicable laws.
4. **Inspections.** An inspection is required before footings can be poured and setbacks verified. A framing inspection is required before installing siding to verify plans are being followed and that proper bracing is used. All projects must receive a final inspection in order to verify that your project exterior meets code, grade is proper and to close out the permit. Remember **YOU** are responsible to get the inspections! If you are unsure during the construction process please contact your Department of Building Safety.

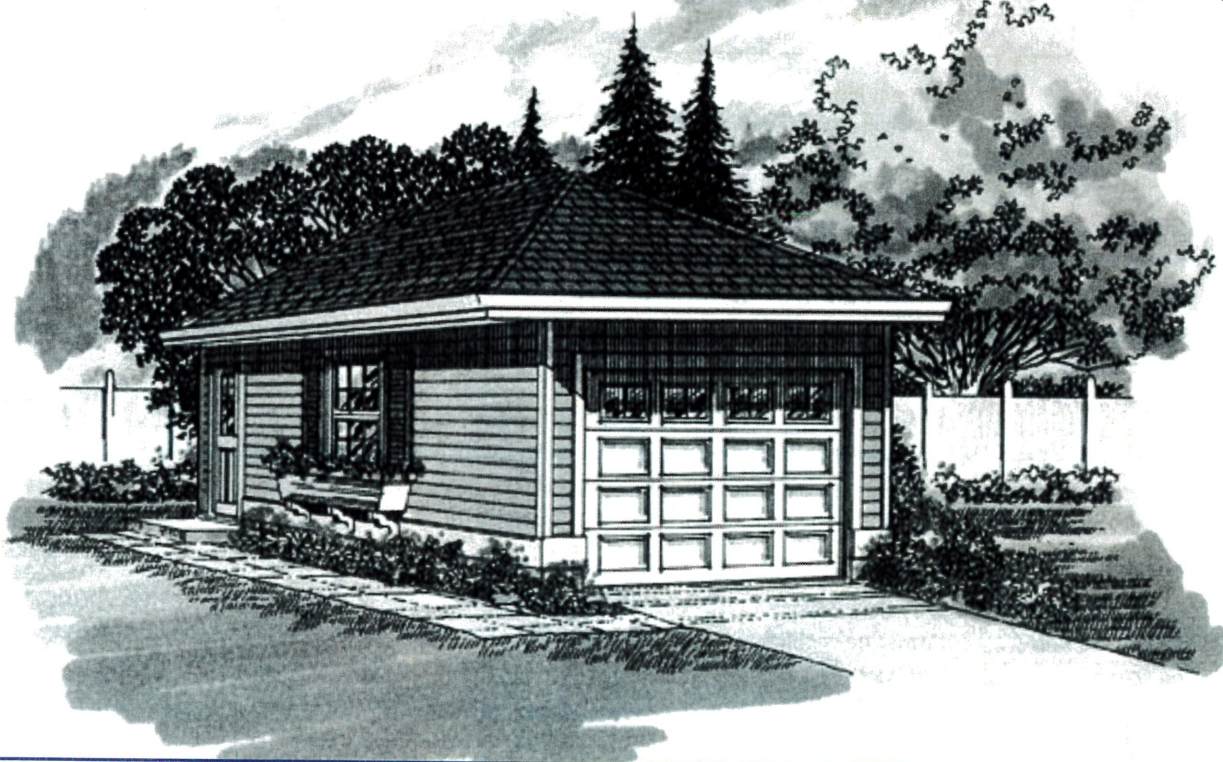

DISCLAIMER: ILLOWA Chapter of the ICC has created this handout to assist with plans submittal under the 2009 International Residential Code, and it is not intended to cover all circumstances. Please check with the Department of Building Safety for additional requirements.

Single Family Residential—One Story Detached Garage

Directions

1. Fill in the blanks on pages 2 and 3 with dimensions and materials which will be used to build the structure. Please print legibly.
2. Indicate in the check box on page 3 which foundation detail from page 4 will be used.

Address:

Note: Heated garages may require special provisions.

Floor Plan

Dimension _____

Locate and detail wall bracing

Indicate rafter or truss direction

✓ Check one

Garage is heated

Garage is not heated

Show door and window header sizes and location and size of landing if more than two risers.

3 1/2" minimum concrete slab all vegetation shall be removed (408.5)

Floor slope back to front not less than 1/8" per ft (IRC 309.1)

Header size _____ x _____ (example (2) 2 x12 or engineered lumber)

Note: If roof trusses or rafters bear on header, special header design may be required

Double 2x4 or 2x6 trimmers each end of overhead door header

Garage door opening

Man Door

Man Door Opening Width

Dimension _____

Garage door opening width _____

Dimension* _____

* See Braced Wall Panel Detail on page 4 to comply with section (IRC 602.10.2)

Dimension* _____

NOTES - Concrete Slab

- All sod and vegetation must be removed.
- If fill is required under slab it must be compacted sand or gravel.
- Floating slab from Detail A and A1 shall be monolithically poured.
- Welded wire fabric or equivalent in slab.
- Minimum 12" perimeter footing (all four sides at least 12" below grade) (IRC 403.1.4).
- Concrete floor or curb to be 6" min. above grade (IRC 404.1.6).
- Floating slab shall be a maximum of 720 sq ft (IRC 403.1.4.1 Exception 1) with no dimension exceeding 30 ft.

Single Family Residential—One Story Detached Garage

Truss' or 2 x ____ rafters spaced ____" o.c.
(example: Put checkmark in box – or 2 x 10 Rafters Spaced 24" O.C.)

Roof sheathing ____
(example: 1/2" exterior plywood) see notes below

Minimum 1 x ____ ridge board
(example 1 x 12)

Roof covering: ____
(example: Class A 3 tab shingles) see notes below

Underlayment: ____
(example: 1 layer 15# felt) see notes below

Building Section

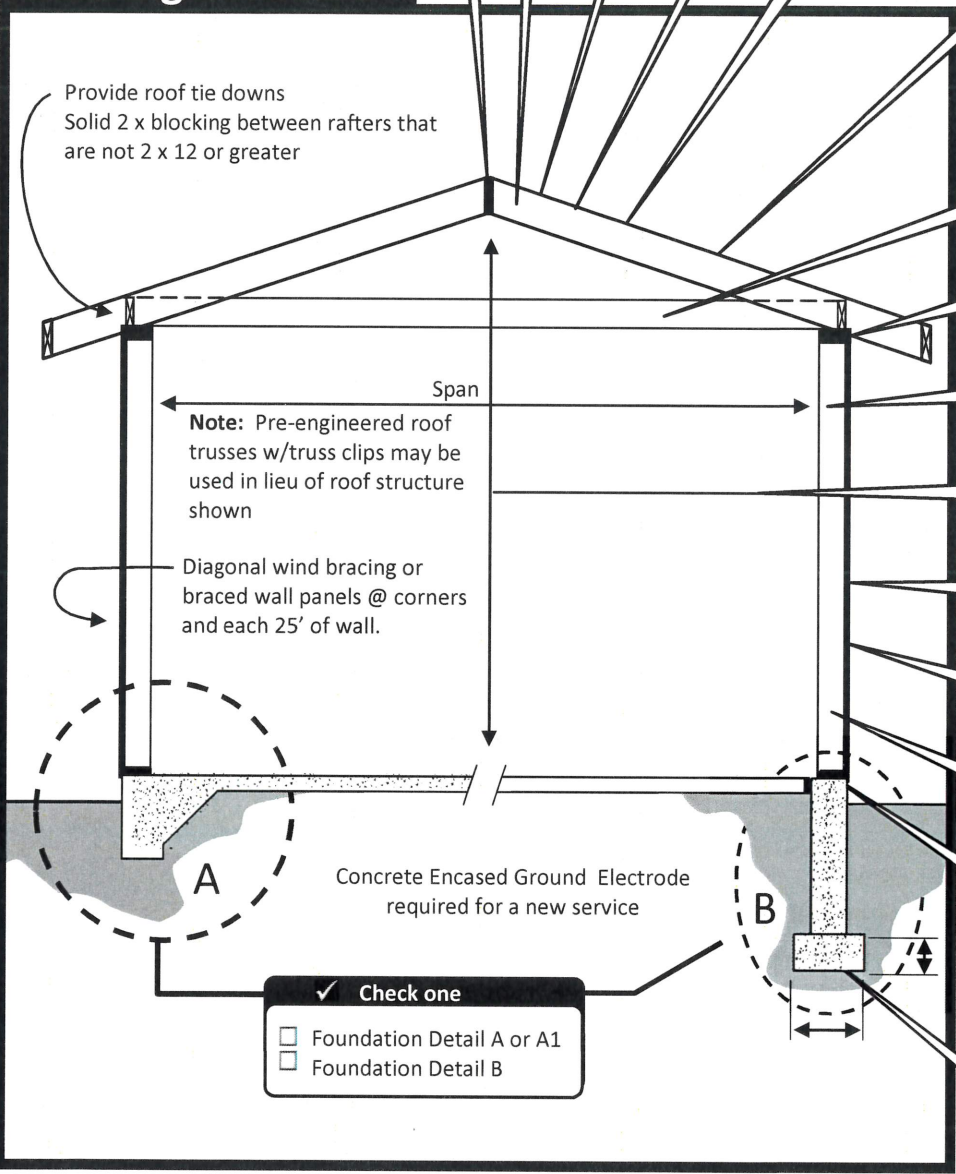

12
pitch ____

Ceiling Insulation: ____
If heated - example: R-38

2 x ____ ceiling joists @ ____ O.C.
(example: 2 x 8 @ 24" O.C.)

Double 2 x ____ top plate
(example: 2 x 6)

Span ____
(example: 23' 5")

Gable mid point height ____
(example: 15')

Siding ____
(example: lap or vinyl)

Wall Sheathing ____
(example: 1/2" exterior plywood)

2 x ____ studs @ ____ O.C.
(example: 2 x 6 @ 24" O.C.)

Cont. 2 x ____ sill plate
(example: 2 x 6)

Wall insulation ____
(If heated—example: R-19 Fiberglass Batts)

Footing size ____ x ____
(example: 8" x 16")

Provide roof tie downs
Solid 2 x blocking between rafters that
are not 2 x 12 or greater

Note: Pre-engineered roof
trusses w/truss clips may be
used in lieu of roof structure
shown

Diagonal wind bracing or
braced wall panels @ corners
and each 25' of wall.

Check one
 Foundation Detail A or A1
 Foundation Detail B

Notes:

- Roof sheathing shall be a minimum of 3/8" plywood, for non-veneer OSB/WB 7/16" is the minimum. Sheathing spanning 16" or 24" on center, structural clips must be provided at the center point of each span (table R503.2.1.1 (1)d).
- For roofs with slopes less than 4:12, follow manufacturer's instructions for low slope application of roofing material.
- Shingles must be rated for 90 MPH and over 15# felt.
- Heated buildings require ice dam barrier applied inside of roof/wall junction.
- Hurricane straps, rafter ties or other tie downs shall be used to attach all roof rafters or trusses to top plates. When double top plates are used, straps or ties must attach to both plates.

DISCLAIMER: ILLOWA Chapter of the ICC has created this handout to assist with plans submittal under the 2009 International Residential Code, and it is not intended to cover all circumstances. Please check with the Department of Building Safety for additional requirements.

Single Family Residential—One Story Detached Garage

Foundation Detail A

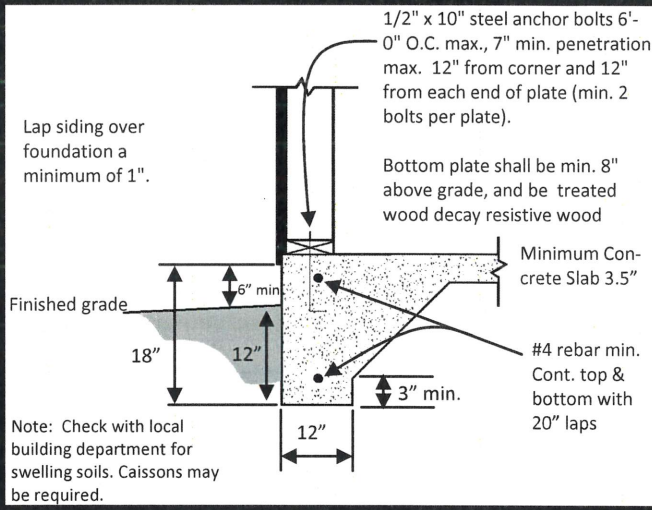

Foundation Detail A1

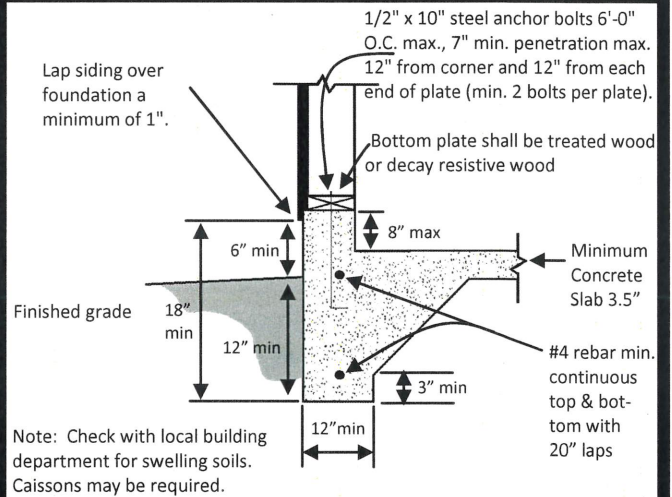

Foundation Detail B

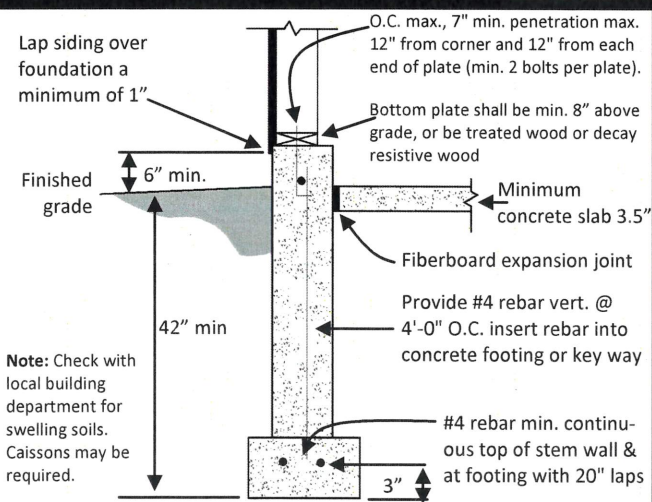

DISCLAIMER: ILLOWA Chapter of the ICC has created this handout to assist with plans submittal under the 2009 International Residential Code, and it is not intended to cover all circumstances. Please check with the Department of Building Safety for additional requirements.

Single Family Residential—One Story Detached Garage

Braced Wall Panel Detail

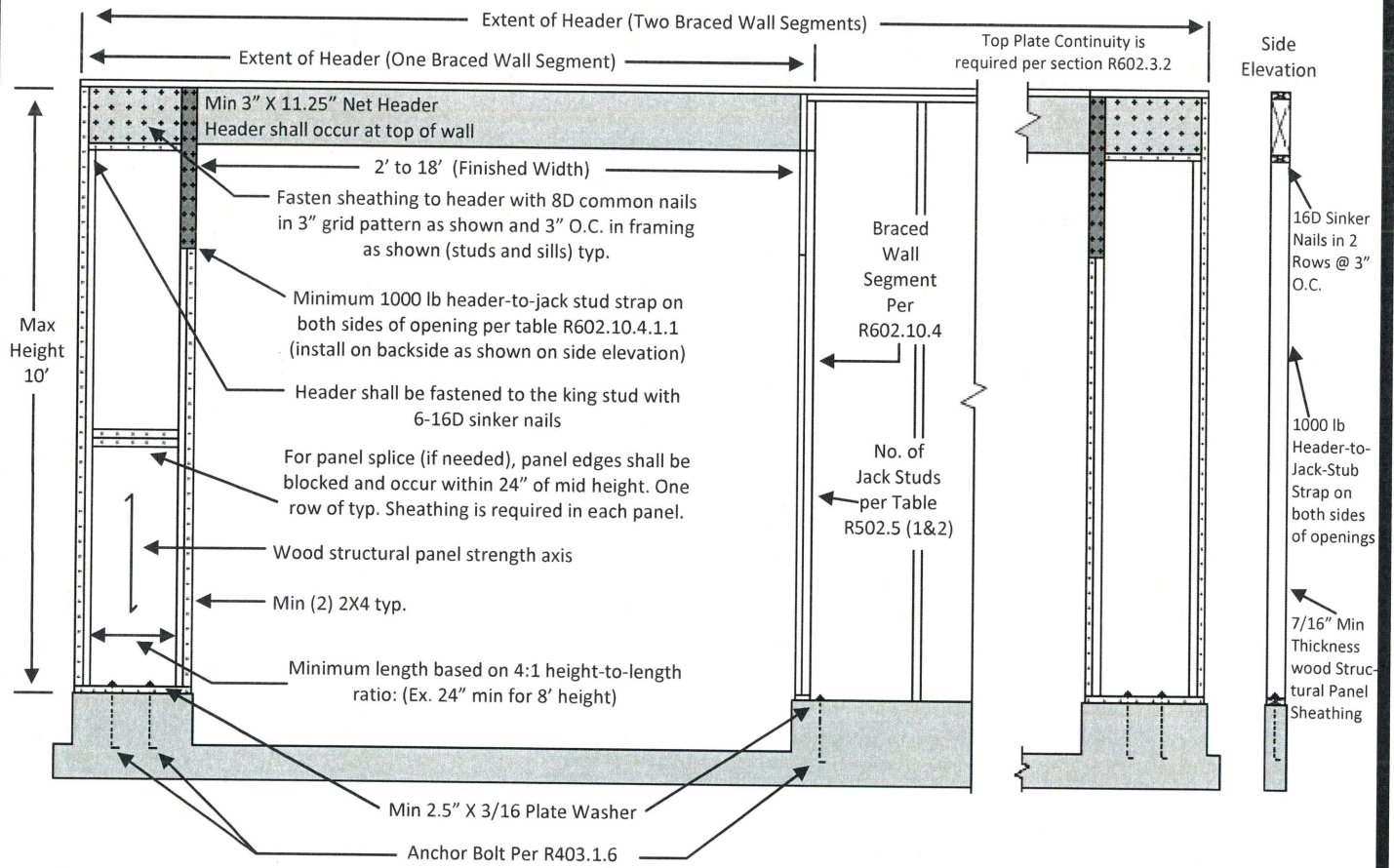

IRC FIGURE R602.10.3.4

Notes:

- For more information on wall bracing go to: www.apawood.org/wallbracing

Construction project notes:
